

## **PTFE EXPANSION JOINTS**

### **Flanged ANSI #150, & PN 10**

The information contained in this publication is intended as a guide to customers, and is freely given in good faith. Whilst every care has been taken in its preparation, the company does not accept responsibility for inaccuracies. Development is continuous. Drawings and specifications may be modified from time to time without notice. Attention is drawn to the company's conditions of sale.

# FLUOROCARBON LININGS FLUOROLINE® EXPANSION JOINTS

## Revisions

Issue No.	Revisions/changes
14	Pressure/temp graph for 2/3 convolute 350-800NB HD added
15	Not issued
16	Re-spaced and edited. Error found in 350-700EHD 2/3 pressure/temp. rating graph. Safe working pressure corrected to 9bar @ 20°C. Graph re-drawn.
17	Pressure/temperature graphs edited for clarification. References to pre PED service conditions removed. Wall thickness data removed
18	9+10 convolution lengths amended references to pages 6 & 12 corrected.
19	Lengths amended for convolutes 1 -10 sizes 25mm-800mm. . FCL logo added. H Appleby

# FLUOROCARBON LININGS FLUOROLINE® EXPANSION JOINTS

## Fluoroline Expansion Joints

### Two and Three Convolutes

Flanges: EN-GJS-400-18-LT

PTFE: ASTM D 4894 Type IV

Support Rings: Stainless steel ASTM A 304L

Limit indicators: Steel with washers and locknuts

Insulating sleeve: Polyethylene (90°C max.),  
PTFE (250°C max.)

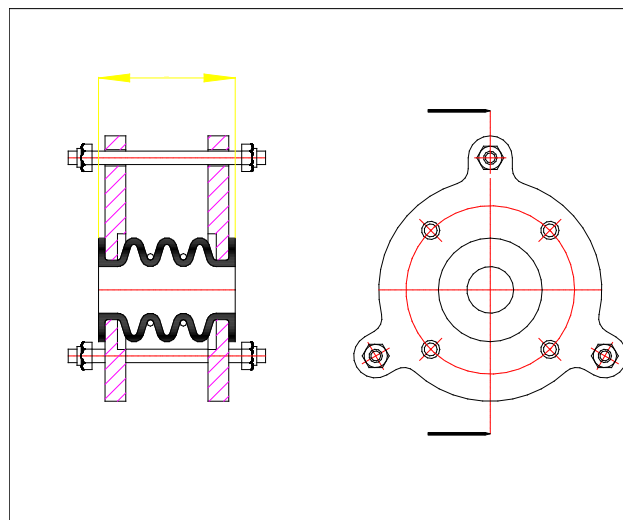

Two Convolutions					Three Convolutions			
Size	Length	Extension/ Compression	Lateral deflection	Angular deflection	Length	Extension/ Compression	Lateral deflection	Angular deflection
mm	mm	+/- mm	mm	degrees	mm	+/- mm	mm	degrees
25	43	7	4	16	43	12	6	19
32	54	8	4	16	54	12	6	18
40	54	8	4	16	54	12	6	18
50	55	11	6	12	55	19	9	16
65	65	11	6	12	65	19	9	16
80	65	13	7	11	65	25	12	15
100	67	15	8	10	67	25	12	14
125	75	15	8	9	75	25	12	12
150	75	16	8	8	75	28	14	11
200	75	17	8	7	75	28	14	10
250	78	19	9	7	78	30	15	10
300	95	19	9	6	95	30	15	10
350	98	20	10	5	98	30	15	8
400	117	20	10	5	117	30	15	8
450	118	20	11	4	118	30	15	6
500	125	20	11	4	125	30	15	6
600	146	18	9	3	130	25	12	5
700	160	25	12	2	146	32	16	3
800	43	25	11	2	160	32	16	3

**NB.** If two or three types of deflection exist simultaneously, the full deflection allowances are reduced  
To estimate the allowable deflections, use the formula on page 14.

# FLUOROCARBON LININGS FLUOROLINE® EXPANSION JOINTS

## Fluoroline Expansion Joints

### Four and Five Convolute

Flanges: EN-GJS-400-18-LT

PTFE: ASTM D 4894 Type IV

Support Rings: Stainless steel ASTM A 304L

Limit indicators: Steel with washers and locknuts

Insulating sleeve: Polyethylene (90°C max.)  
PTFE (250°C max.)

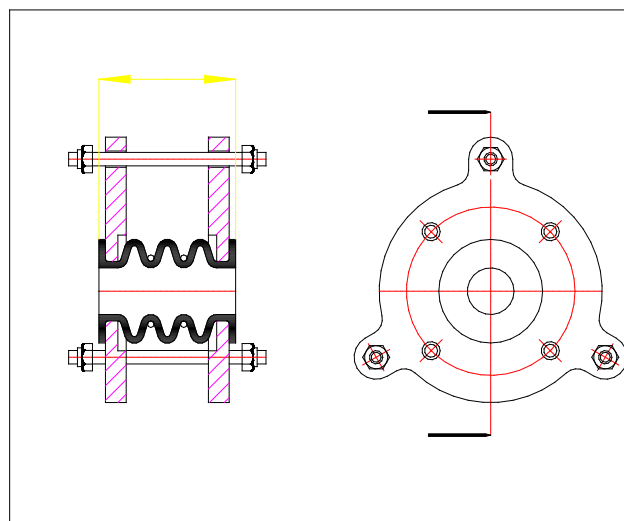

Four Convolutions					Five Convolutions				
Size	Length	Extension/Compression	Lateral deflection	Angular deflection	Length	Extension/Compression	Lateral deflection	Angular deflection	
mm	mm	+/- mm	mm	degrees	mm	+/- mm	mm	degrees	
25	65	15	8	25	76	19	10	30	
32	84	18	8	24	99	24	12	30	
40	84	18	8	24	99	24	12	30	
50	85	23	14	23	100	27	14	26	
65	105	26	15	21	125	30	15	25	
80	105	30	15	19	125	34	17	24	
100	115	30	16	18	139	36	18	22	
125	131	32	16	16	159	37	18	19	
150	131	32	17	15	159	38	19	17	
200	131	33	17	13	159	39	19	15	
250	130	34	18	12	156	39	19	13	
300	169	34	18	11	206	40	20	13	
350	176	34	18	10	215	41	20	12	
400	207	35	18	10	252	42	21	12	
450	208	35	18	8	253	42	21	10	
500	215	35	18	8	260	43	21	10	
600	226	32	15	6	274	43	22	8	
700	268	40	19	4	329	46	23	5	
800	282	40	19	4	343	46	23	5	

**NB.** If two or three types of deflection exist simultaneously, the full deflection allowances are reduced. To estimate the allowable deflections, use the formula on page 14.

# FLUOROCARBON LININGS FLUOROLINE® EXPANSION JOINTS

## Fluoroline Expansion Joints

### Six and Seven Convolutes

Flanges: EN-GJS-400-18-LT

PTFE: ASTM D 4894 Type IV

Support Rings: Stainless steel ASTM A 304L

Limit indicators: Steel with washers and locknuts

Insulating sleeve: Polyethylene (90°C max.)

PTFE (250°C max.)

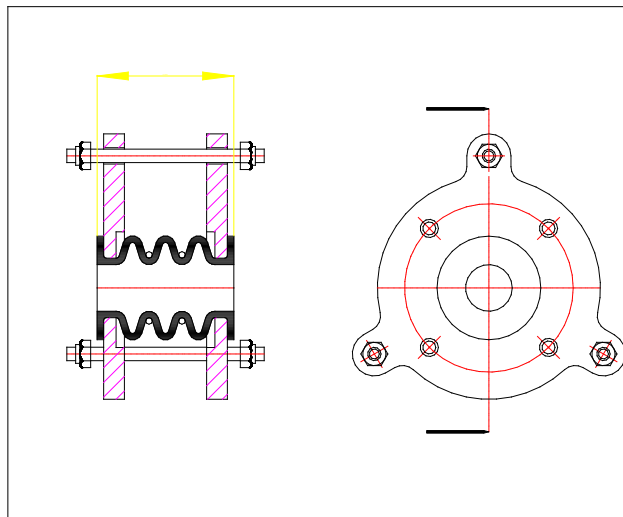

Six Convolutions					Seven Convolutions			
Size	Length	Extension/ Compression	Lateral deflection	Angular deflection	Length	Extension/ Compression	Lateral deflection	Angular deflection
mm	mm	+/- mm	mm	degrees	mm	+/- mm	mm	degrees
25	87	24	12	38	98	30	17	45
32	114	30	15	36	129	35	22	42
40	114	30	15	36	129	35	22	42
50	115	32	17	32	130	39	22	42
65	145	38	19	30	165	42	24	36
80	145	41	20	28	165	45	25	33
100	163	42	21	27	187	48	26	30
125	187	43	21	23	215	49	27	27
150	187	44	22	19	215	50	28	23
200	187	45	22	17	215	51	28	20
250	182	45	23	15	208	52	30	18
300	243	47	23	15	280	53	32	17
350	254	48	24	14	293	55	34	16
400	297	50	25	14	342	59	34	16
450	298	50	25	12	343	60	35	14
500	305	51	25	12	350	60	35	14
600	322	52	26	10	370	62	36	11
700	390				451			
800	404				465			

**NB.** If two or three types of deflection exist simultaneously, the full deflection allowances are reduced.  
To estimate the allowable deflections, use the formula on page 14.

# FLUOROCARBON LININGS FLUOROLINE® EXPANSION JOINTS

## Fluoroline Expansion Joints

### Eight and Nine Convolutes

Flanges: EN-GJS-400-18-LT

PTFE: ASTM D 4894 Type IV

Support Rings: Stainless steel ASTM A 304L

Limit indicators: Steel with washers and locknuts

Insulating sleeve: Polyethylene (90°C max.)  
PTFE (250°C max.)

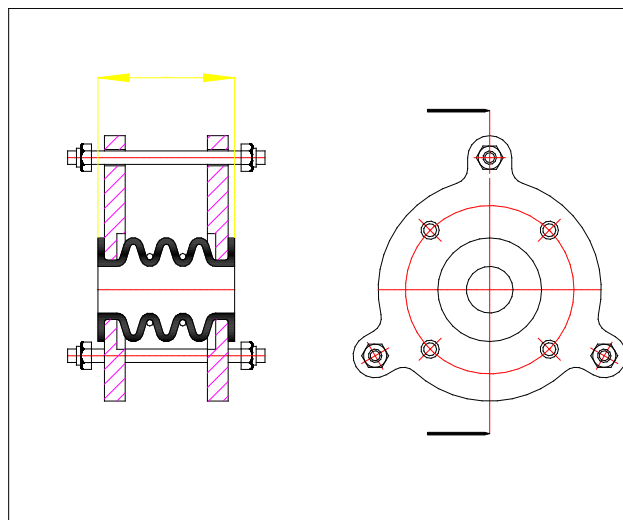

Eight Convolutions					Nine Convolutions			
Size	Length	Extension/ Compression	Lateral deflection	Angular deflection	Length	Extension/ Compression	Lateral deflection	Angular deflection
mm	mm	+/- mm	mm	degrees	mm	+/- mm	mm	degrees
25	109	34	20	51	120	39	23	55
32	144	38	26	47	159	42	31	52
40	144	38	26	47	159	42	31	52
50	145	42	27	46	160	46	32	50
65	185	45	28	41	205	49	33	46
80	185	49	30	37	205	53	35	41
100	211	53	31	34	235	58	36	37
125	243	55	32	31	271	60	37	35
150	243	57	34	27	271	63	40	31
200	243	57	35	23	271	66	41	26
250	234	58	37	21	260	68	43	23
300	317	60	38	20	354	70	44	22
350	332	65	40	18	371	74	46	20
400	387	69	40	18	432	79	46	20
450	388	74	42	16	433	84	47	18
500	395	74	42	16	440	84	48	18
600	418	75	43	13	466	85	49	15
700	512				573			
800	526				587			

**NB.** If two or three types of deflection exist simultaneously, the full deflection allowances are reduced. To estimate the allowable deflections, use the formula on page 14.

# FLUOROCARBON LININGS FLUOROLINE® EXPANSION JOINTS

## Fluoroline Expansion Joints

### Ten Convolute

Flanges: EN-GJS-400-18-LT

PTFE: ASTM D 4894 Type IV

Support Rings: Stainless steel ASTM A 304L

Limit indicators: Steel with washers and locknuts

Insulating sleeve: Polyethylene (90°C max.)

PTFE (250°C max.)

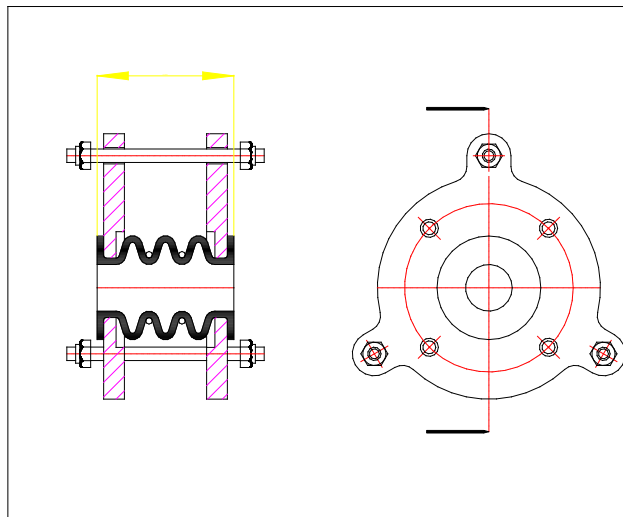

Ten Convolute				
Size	Length	Extension/ Compression	Lateral deflection	Angular deflection
mm	mm	+/- mm	mm	degrees
25	131	44	27	61
32	174	48	35	58
40	174	48	35	58
50	175	51	38	55
65	225	52	39	51
80	225	57	40	45
100	259	63	42	40
125	299	66	44	38
150	299	70	46	35
200	299	74	47	28
250	286	78	48	26
300	391	80	49	24
350	410	85	50	22
400	477	85	50	22
450	478	90	53	20
500	485	90	53	20
600	514	91	56	17
700	634			
800	648			

**NB.** If two or three types of deflection exist simultaneously, the full deflection allowances are reduced.  
To estimate the allowable deflections, use the formula on page 14.

# FLUOROCARBON LININGS FLUOROLINE® EXPANSION JOINTS

## Flange Specifications

Size mm	Thickness mm	Clearance Diameter	DIN PN 10			ANSI #150		
			No. of Tapped Holes	Thread metric coarse	Bolt Circle Diameter	No. of Tapped Holes	Thread UNC ins.	Bolt Circle Dia. ins.
25	14	155	4	M12	85	4	1/2	3 1/8
40	16	190	4	M16	110	4	1/2	3 7/8
50	16	205	4	M16	125	4	5/8	4 3/4
65	16	225	4	M16	145	4	5/8	5 1/2
80	16	240	8	M16	160	4	5/8	6
100	16	260	8	M16	180	8	5/8	7 1/2
125	16	290	8	M16	210	8	3/4	8 1/2
150	18	345	8	M20	240	8	3/4	9 1/2
200	18	400	8	M20	295	8	3/4	11 3/4
250	18	455	12	M20	350	12	7/8	14 1/4
300	18	540	12	M20	400	12	7/8	17
350	20	565	12	M20	460	12	1	18 3/4
400	20	635	16	M24	515	16	1	21 1/4
450	22	695	16	M24	565	16	1 1/8	22 3/4
500	22	740	20	M24	620	20	1 1/8	25
550	24	810	20	M24	675	20	1 1/4	27
600	24	880	20	M24	725	20	1 1/4	29 1/2

## Recommended Bolt Torques Nm.

NPS	ANSI #150	PN10	PN16
25	25	25	25
40	25	25	25
50	45	45	45
65	46	46	46
80	48	48	48
100	55	50	50
125	110	80	80
150	115	90	90
200	100	115	80
250	120	95	110
300	125	115	150
350	200	140	160
400	255	155	200
500	220	160	200
600	290	190	235

# FLUOROCARBON LININGS FLUOROLINE® EXPANSION JOINTS

## Pressure/Temperature Ratings (S.E.P. Service)

S.E.P. qualified bellows may be supplied where the service pressure does not exceed 0.5 bar gauge, or the line fluids are categorised as non-hazardous in the EC Pressure Equipment Directive 97/23/EC

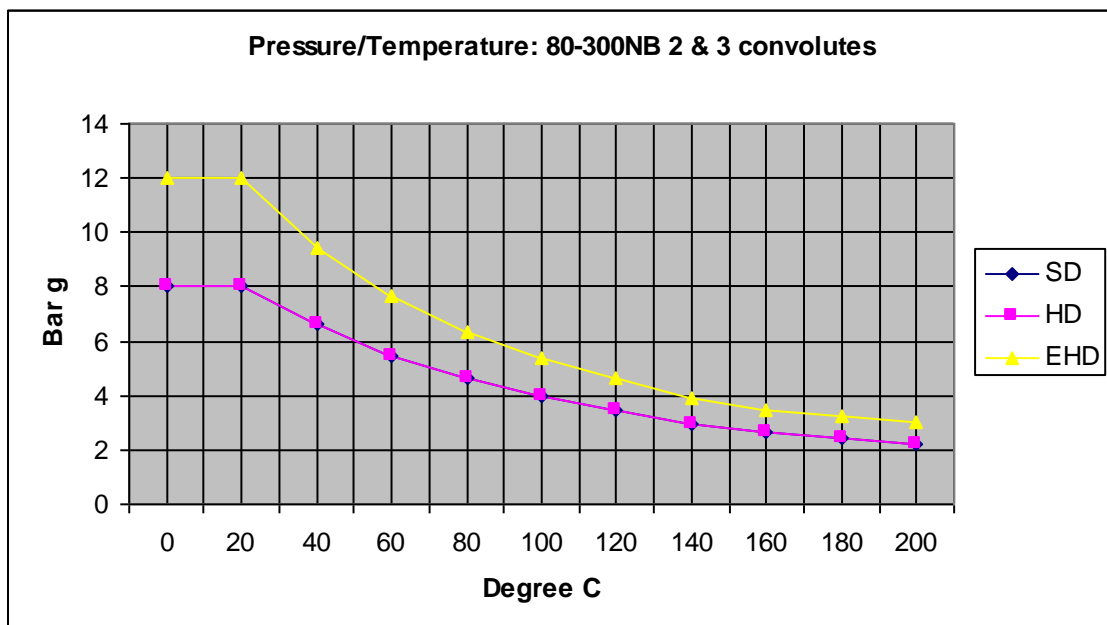
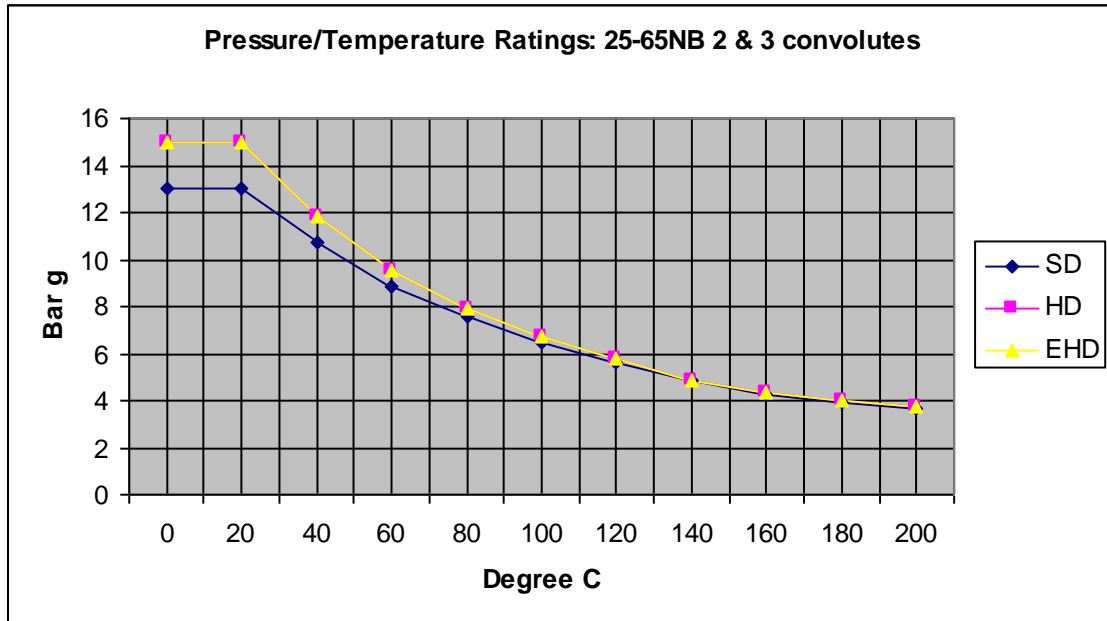

# FLUOROCARBON LININGS FLUOROLINE® EXPANSION JOINTS

## Pressure/Temperature Ratings (Categories 1- 3 Service)

### for 2 & 3 Convolute Expansion Joints

Restrictions on sizes, pressures and fluids apply in the E.U. as defined in the EC Pressure Equipment Directive 97/23/EC

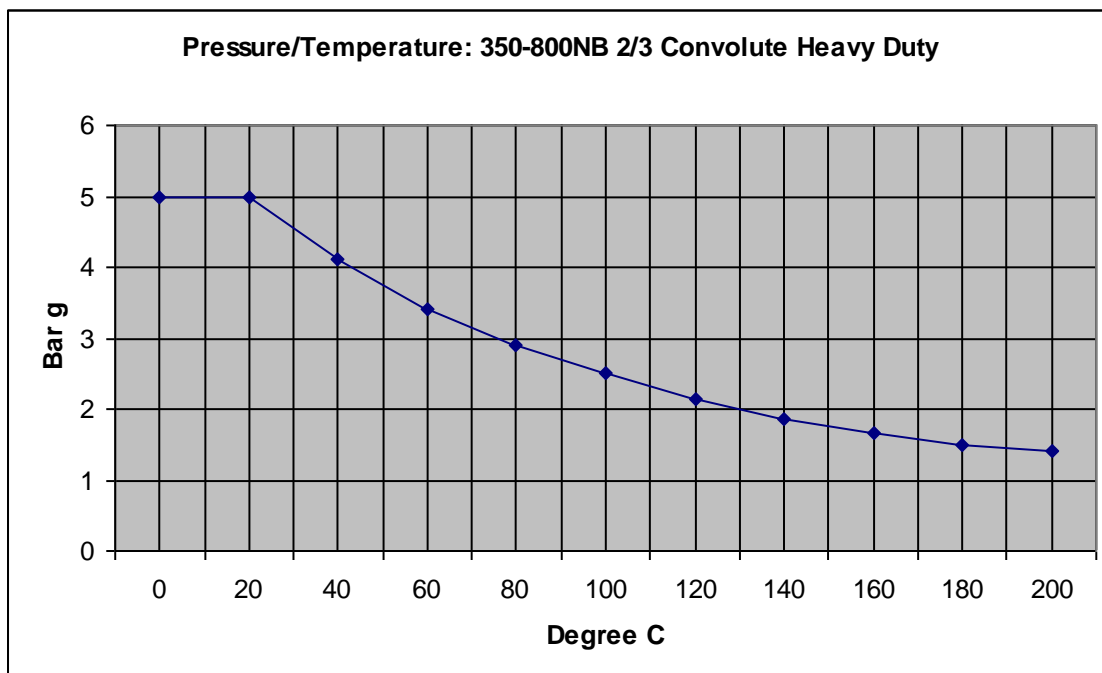
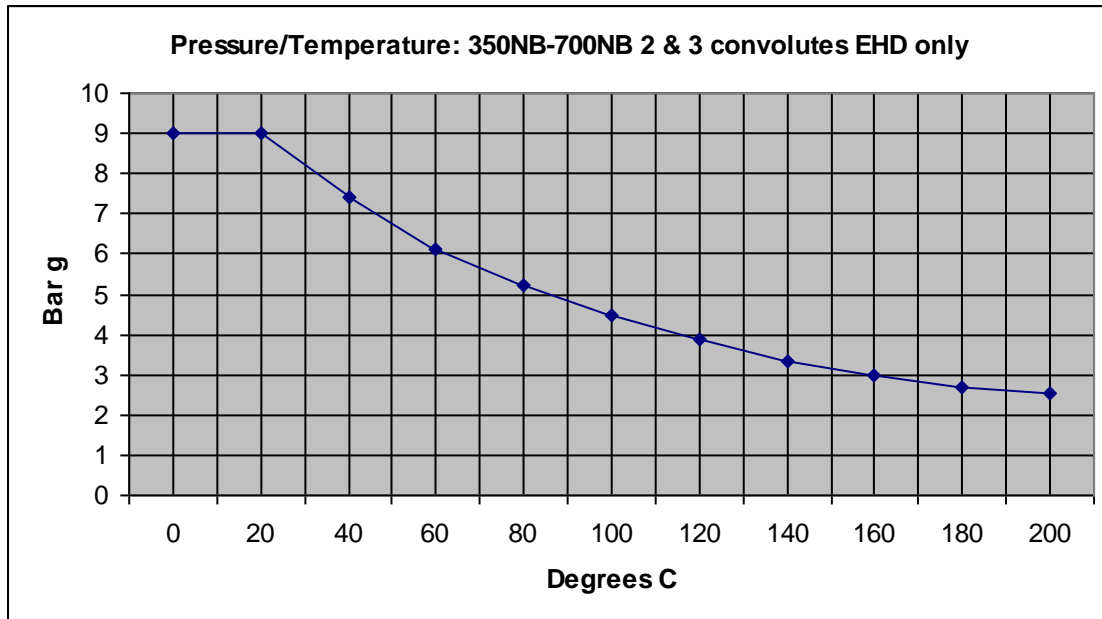

# FLUOROCARBON LININGS FLUOROLINE® EXPANSION JOINTS

## Pressure/Temperature Ratings (Categories 1- 3 Service)

### for 4 & 5 Convolute Expansion Joints

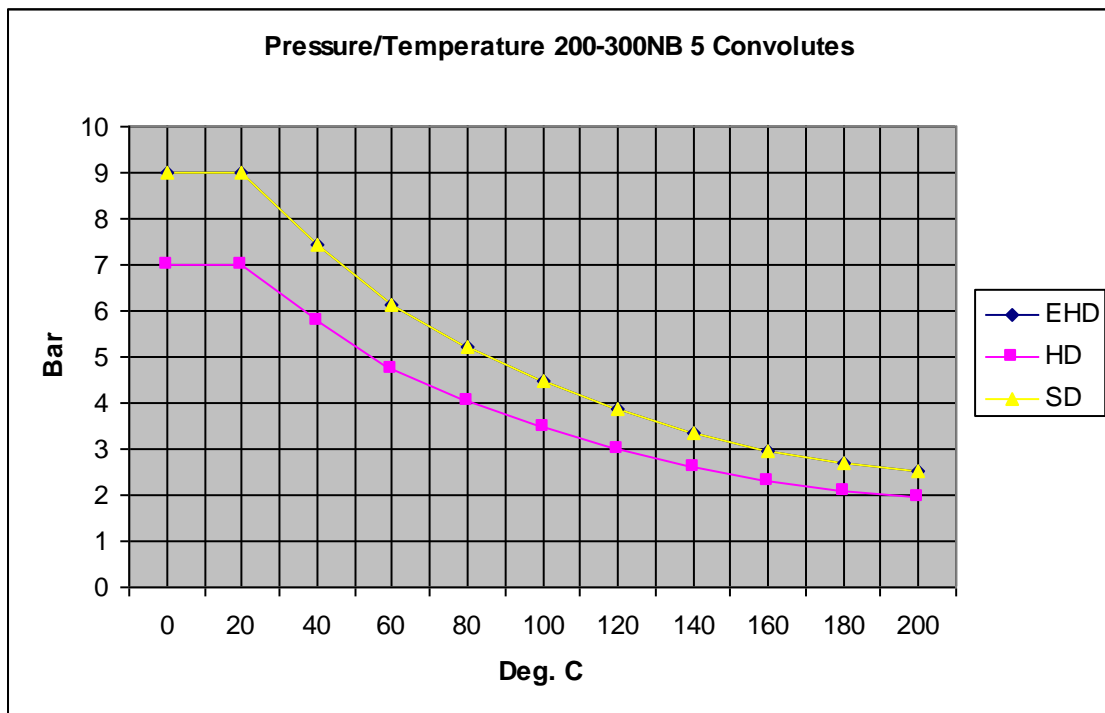
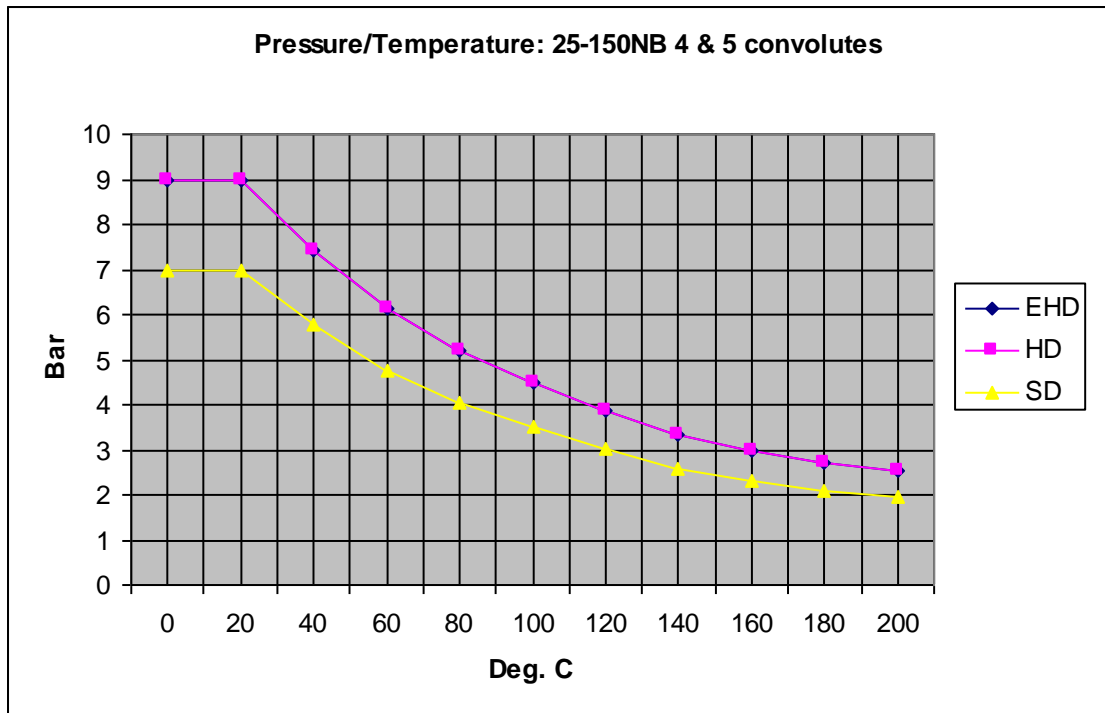

# FLUOROCARBON LININGS FLUOROLINE® EXPANSION JOINTS

## Vacuum Service

Units in the table below are rated to full vacuum at the stated temperature

Duty	Nominal Size	2 Convolutions	3 Convolutions
Heavy Duty	25 - 65	200 <sup>0</sup> C	200 <sup>0</sup> C
	80 - 300	80 <sup>0</sup> C	80 <sup>0</sup> C
Extra Heavy Duty	25 - 65	200 <sup>0</sup> C	200 <sup>0</sup> C
	80 - 300	100 <sup>0</sup> C	100 <sup>0</sup> C

Units having four or more convolutions are not recommended for vacuum service.

## Retained Properties of PTFE/Temperature

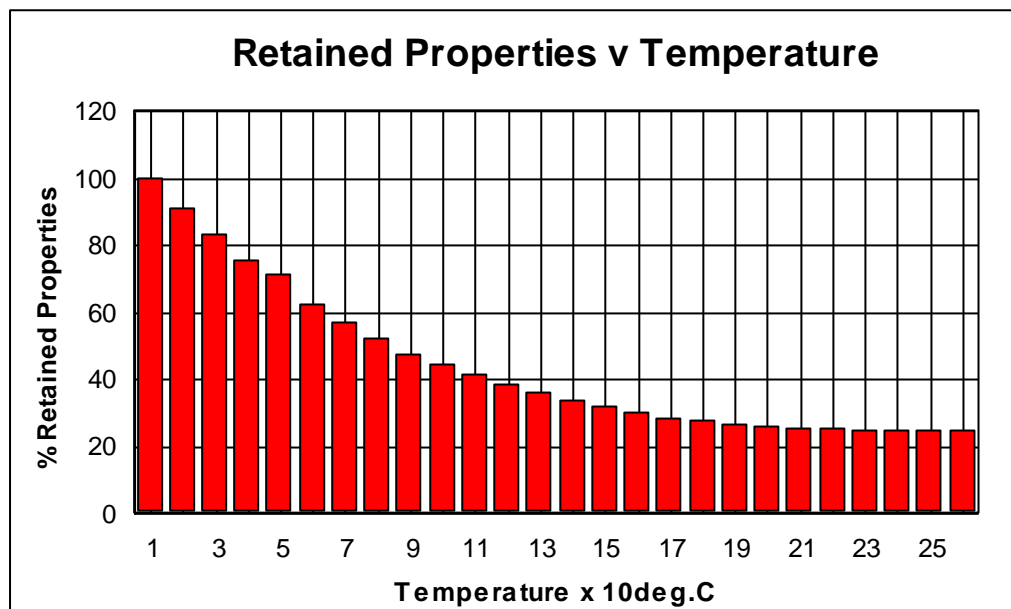

# FLUOROCARBON LININGS FLUOROLINE® EXPANSION JOINTS

## Movement Force Data (kN/mm)

### 2 Convolute Expansion joints

Size	Extension			Compression			Lateral		
	Std. Duty	Heavy Duty	Extra Duty	Std. Duty	Heavy Duty	Extra Duty	Std. Duty	Heavy Duty	Extra Duty
25	0.10	0.17	0.17	0.10	0.26	0.26	0.17	0.41	0.41
40	0.10	0.17	0.17	0.10	0.26	0.26	0.17	0.41	0.41
50	0.10	0.17	0.17	0.20	0.35	0.35	0.17	0.41	4.1
65	0.10	0.17	0.17	0.20	0.38	0.38	0.17	0.41	0.41
80	0.10	0.19	0.19	0.30	0.46	0.46	0.19	0.45	0.45
100	0.10	0.2	0.22	0.30	0.46	0.7	0.19	0.48	0.72
125	0.10	0.23	0.27	0.30	0.54	0.93	0.23	0.53	1.07
150	0.10	0.26	0.33	0.30	0.64	1.21	0.32	0.69	1.55
200	0.20	0.31	0.43	0.30	0.74	1.58	0.46	0.89	2.2
250	0.20	0.35	0.52	0.40	0.87	1.94	0.47	0.97	2.54
300	0.20	0.41	0.62	0.40	0.41	2.37	0.57	1.11	3.03
350	0.40			0.50			0.9		
400	0.50			0.90			1.46		
450	0.80			1.30			2.11		
500	1.10			1.60			2.6		
600	1.50			2.20			3.8		
700	2.00			2.90			5.1		
800	2.30			3.20			5.88		

### 3 Convolute Expansion Joints

Size	Extension			Compression			Lateral		
	Std. Duty	Heavy Duty	Extra Duty	Std. Duty	Heavy Duty	Extra Duty	Std. Duty	Heavy Duty	Extra Duty
25	0.04	0.1	0.1	0.06	0.15	0.15	0.11	0.28	0.28
40	0.04	0.1	0.1	0.08	0.17	0.17	0.11	0.28	0.28
50	0.04	0.1	0.1	0.11	0.2	0.2	0.11	0.28	0.28
65	0.04	0.1	0.1	0.13	0.22	0.22	0.11	0.28	0.28
80	0.04	0.1	0.1	0.16	0.24	0.24	0.11	0.28	0.28
100	0.04	0.12	0.13	0.16	0.24	0.42	0.11	0.33	0.58
125	0.06	0.14	0.16	0.17	0.27	0.56	0.15	0.35	0.73
150	0.07	0.15	0.19	0.18	0.31	0.69	0.18	0.39	0.86
200	0.10	0.19	0.26	0.20	0.39	0.96	0.26	0.49	1.22
250	0.11	0.22	0.33	0.22	0.47	1.23	0.28	0.56	1.47
300	0.13	0.26	0.39	0.25	0.55	1.5	0.34	0.68	1.85
350	0.23			0.34			0.6		
400	0.32			0.58			0.97		
450	0.53			0.86			1.55		
500	0.70			1.07			1.91		
600	1.07			1.55			2.85		
700	1.43	2.86		2.08	7.80		3.83		
800	1.65			2.32			4.41		

# FLUOROCARBON LININGS FLUOROLINE® EXPANSION JOINTS

## 5 Convolute Expansion Joints

Size	Extension			Compression			Lateral		
	Std. Duty	Heavy Duty	Extra Duty	Std. Duty	Heavy Duty	Extra Duty	Std. Duty	Heavy Duty	Extra Duty
25	0.03	0.06	0.06	0.04	0.09	0.09	0.07	0.14	0.14
40	0.03	0.06	0.06	0.04	0.09	0.09	0.07	0.14	0.14
50	0.03	0.07	0.07	0.08	0.14	0.14	0.07	0.16	0.16
65	0.03	0.07	0.07	0.08	0.14	0.14	0.07	0.16	0.16
80	0.03	0.07	0.07	0.12	0.18	0.18	0.08	0.19	0.19
100	0.03	0.08	0.09	0.12	0.18	0.29	0.08	0.21	0.34
125	0.04	0.09	0.11	0.12	0.18	0.38	0.1	0.23	0.48
150	0.05	0.11	0.14	0.13	0.23	0.51	0.13	0.29	0.63
200	0.07	0.14	0.19	0.14	0.28	0.69	0.19	0.38	0.94
250	0.08	0.17	0.25	0.17	0.36	0.95	0.22	0.47	1.23
300	0.10	0.2	0.29	0.19	0.41	1.13	0.26	0.52	1.43
350	0.17			0.25			0.45		
400	0.23			0.41			0.69		
450	0.38			0.61			1.11		
500	0.70			0.75			1.3		
600	1.07			0.90			1.55		
700	1.43			1.21			2.09		
800	1.65			1.35			2.41		

## Permitted compound deflection formula

Let  $\Delta l$  be the change in length (extension)

Let  $\Delta m$  be the lateral misalignment

Let  $\Delta r$  be the angular displacement

$\Delta_{max}$  indicates the permitted maximum displacement

$$\left\{ \frac{\Delta l}{\Delta l_{max}} + \frac{\Delta m}{\Delta m_{max}} + \frac{\Delta r}{\Delta r_{max}} \right\} \leq 1$$

## Effective Cross-Sectional Area

Nominal Size	Effective Area cm <sup>2</sup>	Internal Diameter mm
25	10	25
40	16	36
50	26	49
65	47	64
80	58	76
100	85	95
125	137	122
150	199	145
200	342	193

Nominal Size	Effective Area cm <sup>2</sup>	Internal Diameter mm
250	518	241
300	746	293
350	1019	345
400	1322	391
450	1670	439
500	2058	488
600	2956	586
700	4016	683
800	5238	781

# FLUOROCARBON LININGS FLUOROLINE® EXPANSION JOINTS

## Options

### Liner Tube

- √ Standard Duty.
- √ Heavy Duty.
- √ Extra-Heavy Duty.
- √ Static Dissipating.

### Flange Material

- √ Stainless Steel.
- √ Carbon Steel.

### Flange Drillings

- √ To client's specification.
- √ Oversize flanges for Carbon Block Heat Exchangers.

### Reinforcing Rings

- √ Hastelloy.
- √ Monel.

## On-Site Precautions

### Handling and Storage

PTFE expansion joints are easily damaged in handling, having no external metal housings. Great care must be taken when they are being moved, or in storage.

The flare protection covers serve to shield the sealing flare faces from impact damage, and to restrain the flares in a flat position.

Flare covers should be immediately replaced if removed for any reason, and then finally removed immediately prior to installation.

### Unpacking and Checking

PTFE expansion joints should be unpacked on arrival, and visually checked for damage, which may have occurred in transit. Items will have undergone a rigorous test and inspection procedure before dispatch from the factory.

This operation should be carried out under cover, in a clean area.

### Installation

Before installation adjoining pipework must be checked for firm support and anchorage to prevent overstretching or compression of the unit during installation and subsequent service.

# FLUOROCARBON LININGS

## FLUOROLINE® EXPANSION JOINTS

It is good practice to install with the limit rods in position. However it should be noted that these rods might not prevent excessive movement due to pipework movements in service.

Mating flanges must be within the travel and angular movement limits prior to installation, and gaps should be dimensioned so that the unit is in a position close to its median dimensions when in service.

Installation is the same as for PTFE lined piping, with subsequent checking of bolt torques after installation.

Bolt torques are specified on page 8 of this section.

PTFE installation is defined in section FMS 33 in the catalogue.

### **Welding**

**Because of the risk of damage to the PTFE, welding close to these items must be avoided.**

### **Physical Damage**

The PTFE components in these items are easily damaged. Consideration may be given to fitting them with shrouds and guards, to prevent damage and minimise risk of uncontrolled fluid escapes.

### **In-Service Inspection**

These items should be inspected visually on a regular basis, as with all plastic lined systems.

It is recommended that bolts be re-tightened after the first and second thermal cycles to counteract creep that may have taken place in the flares.